



Помпа потопяема дренажна за фекални и отпадни води City Pumps TITAN 15/50

RANGE OF PERFORMANCE

Flow rate up to 1200 l/min (72 m³/h)
Head up to 16 m

LIMITS OF USE

Depth up to 10 m
Liquid temperature up to + 40°C
Passage of solid bodies max Ø 50 mm for TITAN 15-20-30/50
Passage of solid bodies max Ø 70 mm for TITAN 15-20-30/70
For continuous duty: minimum immersion 420 mm from pump base

INSTALLATION AND USE

TITAN SERIES PUMPS ARE MADE OF EXCEPTIONALLY ROBUST HEAVY-GAUGE CAST IRON, RESISTANT TO ABRASION AND LONG-LASTING, AND HAVE A VORTEX TYPE IMPELLER. THEY ARE SUITABLE FOR SEWAGE, WASTE WATER AND SLUDGE, INCLUDING WATER CONTAINING SOLIDS OR MUD. THEY ARE IDEAL FOR SEWAGE INSTALLATION, TUNNELS AND OTHER EXCAVATIONS, UNDERGROUND CARPARKS AND SIMILAR APPLICATIONS.

GUARANTEE 2 YEARS subject to our general terms of sale.

CONSTRUCTION CHARACTERISTICS

- PUMP BODY, MOTOR CASING: cast iron.
- IMPELLER: cast iron.

- **BASE:** stainless steel AISI 304.
 - **MOTOR SHAFT:** vortex, stainless steel EN 10088-3 - 1.4057.
 - **DOUBLE SEAL:** mechanical seal **silicon carbide - widia -NBR**, with oil barrier chamber and inner lip seal to protect the seal in the event of dry running.
 - **MOTOR:** submersible asynchronous, 2 pole, for continuous duty.
- TITAN M:** single-phase 220÷240 V - 50 Hz Models up to 1.5 kW have built in thermal protection 2.2 kW single-phase versions have a thermal protector provided in the winding for connection to the control box.
- TITAN:** three-phase 380÷415 V - 50 Hz. Thermal protectors are provided in the winding for connection to the external control panel
- **INSULATION:** class F.
 - **PROTECTION:** IP 68.

STANDARD FEATURES:

- **TITAN M** (single-phase)
 - Float switch.
 - **10 metres** "H07 RN-F" submersible power cable with Schuko plug.
 - 1,1 to 1.5 kW models are supplied with control box with capacitor and manual reset motor protector. 2.2 kW models are supplied with control box type QES 300 MONO.
- **TITAN** (three-phase)
 - **10 metres** "H07 RN-F" neoprene power cable



OPTIONS ON REQUEST

- ⇒ control box for three-phase pumps
- ⇒ dual voltage: 230/400 V or 400/690 V
- ⇒ single-phase versions without float switch
- ⇒ other voltages or frequency 60 Hz

CONSTRUCTION AND SAFETY STANDARDS

EN 60034-1

IEC 34-1

CEI 2-3



DIMENSIONS

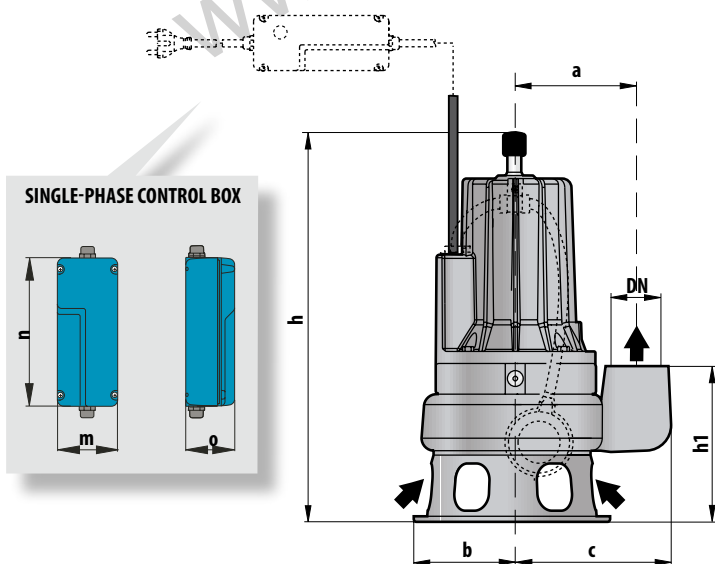

SINGLE-PHASE CONTROL BOX

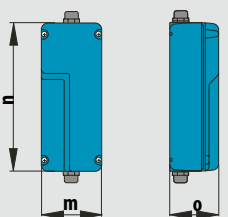

Typical single-phase installation

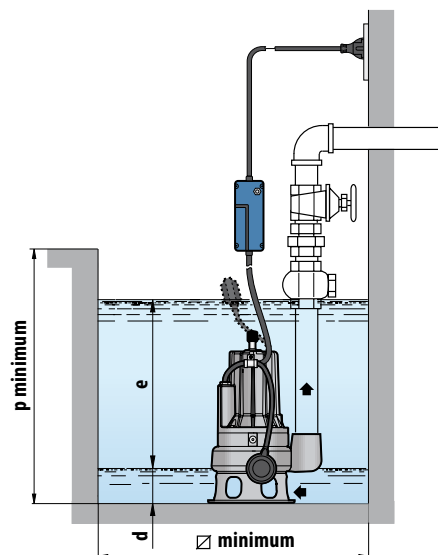



TITAN 50-70

VORTEX submersible pumps

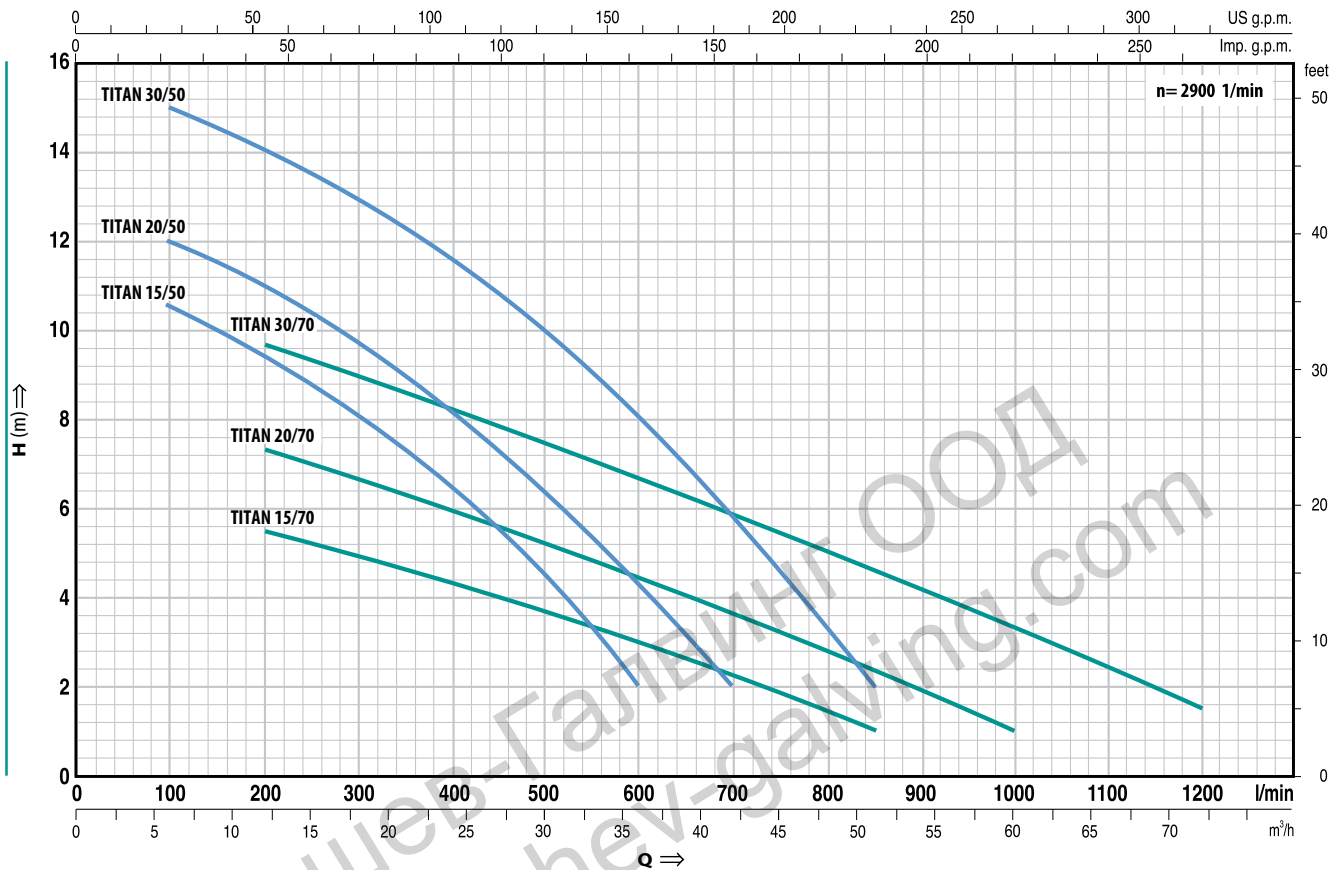

Q = Flow rate H = Total manometric head

Tolerance of the performance curves according to EN ISO 9906 App. A.

TYPE		POWER		m³/h l/min	H metres															
Single-phase	Three-phase	kW	HP		0	6	12	18	21	24	30	36	42	48	51	54	60	66	72	
				0	100	200	300	350	400	500	600	700	800	850	900	1000	1100	1200		
TITAN 15/50M	TITAN 15/50	1.1	1.5	11.5	10.5	9.5	8.2	7.2	6.5	4.5	2									
TITAN 20/50M	TITAN 20/50	1.5	2	13	12	11	9.5	9	8	6.5	4.5	2								
TITAN 30/50M	TITAN 30/50	2.2	3	16	15	14	13	12.3	11.5	10	8	5.9	3.3	2						
TITAN 15/70M	TITAN 15/70	1.1	1.5	6.5	---	5.5	5	4.7	4.4	3.7	3	2.2	1.5	1						
TITAN 20/70M	TITAN 20/70	1.5	2	8.5	---	7.4	6.7	6.3	6	5.2	4.5	3.6	2.8	2.4	2	1				
TITAN 30/70M	TITAN 30/70	2.2	3	11	---	9.7	9	8.6	8.2	7.5	6.7	5.8	5	4.6	4.2	3.3	2.5	1.5		

DIMENSIONS AND WEIGHTS

TYPE		PORT DN	passage of solid bodies	DIMENSIONS mm												kg	
Single-phase	Three-phase			a	b	c	h	h1	m	n	o	d	e	p	∅	1~	3~
TITAN 15/50M	TITAN 15/50	2 1/2"	∅ 50 mm	162	135	212	490	188	81	200	85	75	adjust- able	800	800	33.3	31.0
TITAN 20/50M	TITAN 20/50						500/490									34.8	33.3
TITAN 30/50M	TITAN 30/50						500/490									40.7	34.8
TITAN 15/70M	TITAN 15/70	3"	∅ 70 mm	180	150	240	530	230	81	200	85	85	adjust- able	800	800	38.9	36.6
TITAN 20/70M	TITAN 20/70						540/530									40.8	38.9
TITAN 30/70M	TITAN 30/70						540/530									47.0	41.1